

The United Graduate School of Agricultural Sciences, Tottori University
Guide for submitting a Doctoral dissertation

I Requirements for submitting a dissertation

(1) Course Doctoral

- ① Students who have studied for 2years and 8 months or over in UGSAS under tuition for the doctor's program and get more than 12credits (the students who entered before Mar. 31 2008 must attend seminars for 60 hours or over).
- ② Students who have studied more than 1year and 8 months and achieve very high standards in their research activities, and are recommended by their major supervisors.
- ③ Applicants who had left UGSAS with completion of three or more years in UGSAS and obtainment of at least 12credits including 9credits of required subjects under necessary supervision. Doctoral thesis application must be submitted within three years from the date of having left UGSAS.

In addition to the qualifications for submission in ①, ② and ③ above, the applicant must have two or more academic papers related to the doctoral dissertation in Japanese or English published in academic journals issued by the professional societies.

- a) If the academic paper is a co-authored paper, the applicant must be a first author and the co-author(s) must not have applied for the doctoral dissertation to any university in the past.
- b) The Academic papers can include one that was published two years before entering the UGSAS , but it is limited to one that forms part of a dissertation.
- c) The Academic papers may include one with equally contributed authors by submitting a statement of reasons (optional form) and obtaining approval from the Graduate School Committee, but it is limited to that which forms part of a dissertation. Here, there are no restrictions on the number of first authors or the order of authorship of the applicants in academic papers with equally contributed authors.

【Patterns of Academic Papers acceptable for the Doctoral dissertation application】

Patterns	Two years before entering the UGSAS	After enrollment	Application for Doctoral dissertation
①		Single ・ Single	Acceptable
②	Single (one which forms part of a dissertation)	Single	Acceptable
③		Single ・ Equally contributed (should submit the state of the reason)	Acceptable
④	Equally contributed (should submit the state of the reason)	Single	Acceptable
⑤	Single	Equally contributed	NOT acceptable
⑥	Equally contributed	Equally contributed	NOT acceptable

Single: Academic paper with a first author

Equally contributed: Academic paper with Equally contributed authors

※The applicant's affiliation in the academic paper should be the United Graduate School of Agricultural Sciences, Tottori University.

(2) Dissertation Doctorate

Passing the doctoral degree application qualification assessment. (See Appendix for qualification assessment application criteria.)

In lieu of above, at least four publications closely related to their PhD dissertation in peer-reviewed, academic journals in Japanese or English. **These can not include academic papers with equally contributed authors.**

II Submission period

(1) Students who intend to obtain a Doctor's Degree within the years required for completing their course of study (3 years) :

Applicants should submit their dissertation before the middle of December for April admission (the middle of June for October admission) of the third year of UGSAS.

(2) Students who are studying over three years, those who are qualified for I(1)②, ③, or applicants for Dissertation Doctorate :

Applications can be submitted at any time, though, doctoral degrees shall be conferred twice a year, in September and March. Please be sure to submit documents for application by the specified date. Please note that those who are qualified for I(1)② should pass the preliminary review board.

(3) Students who drop out UGSAS after they submit their dissertation :

Dissertation result shall be decided at the next General Academic Staff Meeting and their completion will be dated back to their leaving date.

III Documents to submit

(1) Course Doctoral

- | | | |
|---|--|-------------|
| ① | Application for doctoral degree (Form No. 1-1) | 1 copy |
| ② | List of publications (Form No. 2, also of sub publications) | 1 copy |
| ③ | Doctoral dissertation (in Japanese or in English) | 1 copy |
| ④ | Summary of doctoral dissertation
(Form No. 3: About 2,000 characters in Japanese or about 1,200 words in English
in 2 A4 papers. | 1 copy |
| ⑤ | Articles related to the doctoral dissertation published in academic
journals, and other articles that serve as references. | Each 1 copy |
| ⑥ | Curriculum vitae (Form No. 4) | 1 copy |
| ⑦ | If papers related to the dissertation have not yet been published,
submit official letters confirming that the articles will be
published or the publisher's contract. | Each 1 copy |
| ⑧ | If papers related to the dissertation have co-authors, summaries
of joint-worked publication (Form No.5) | Each 1 copy |
| ⑨ | Agreement (extent undertaken by the applicant letters of consent
from co-authors) (Form No. 6) | Each 1 copy |
| ⑩ | Notification Form of Internet Publication of Doctoral Dissertation (Form No. 15) | 1 copy |
| ⑪ | If the full text cannot be published through the Internet,
application for publication of doctoral dissertation (Form No. 12) | 1 copy |
| ⑫ | Electronic File of ②, ④, ⑥, ⑧(in MS Word format) and ③, ⑤ (in PDF format) | |
| ⑬ | Examination Fee : Only for the applicants who apply to 1(1)③
and not exceed one year after having left UGSAS | 57,000 yen |

※ If the applicant is unable to submit a letter of acceptance for publication of the academic paper at the time of application for the doctoral degree, the applicant must submit a certificate of submission showing that the paper has been or will be published, by 17:00 on the two days before the date of the dissertation defense (excluding holidays).

(2) Dissertation Doctorate

- | | | |
|-----|---|-------------|
| ① | Application for doctoral degree (Form No. 1-2) | 1 copy |
| ②~⑫ | Same as (1)Course Doctoral | |
| ⑬ | Certificate of Final School Graduated | 1 copy |
| ⑭ | Certificate of Research History (Form No. 7) | Each 1 copy |
| ⑮ | Recommendation from a Major-Supervisor | 1 copy |
| ⑯ | Proposal for the examination of foreign language (Form No. 8) | 1 copy |
| ⑰ | Examination Fee | 57,000 yen |

IV Submission procedures

(1) All documents should be submitted in person or by mail to the Academic Affairs Section of the United Graduate School of Agricultural Sciences, Tottori University.

- (2) Payment of examination fee should be cleared on the day whose application was approved by the President of Tottori University.
- (3) Students intending to submit dissertation must consult with and obtain the permission of the major - supervisor first.

V Guidelines for doctoral dissertation, Summary of doctoral dissertation, and related papers

(1) Doctoral dissertation

- ①The dissertation should be printed on A4 size white paper. A typed version is preferred.
- ②Temporary binding is acceptable for the dissertation when first submitted. After passing the dissertation defense, one bound-cover dissertation (two bound-cover theses if the UGSAS approves the request not to publish the full text on the Internet within a year after the date of conferment of a doctoral degree.) must be submitted at least one week before the doctorate conferment ceremony and they should meet the following requirements.

Color and kind of cover paper:	Not specified
Font color:	Black
Size:	30cm(long)×21cm(wide) (standard A4 size paper)
- ③If the dissertation is written in Japanese, the Japanese title on the front cover should be followed by an English title in parentheses. If the dissertation is written in English, the English title on the front cover should be followed by a Japanese title in parentheses.
- ④The cover must also have the name of the author and the year of the final submission of the dissertation (i.e., submission of bound-cover copy after passing the examination).
- ⑤English and Japanese summaries should be provided on the last page of the dissertation.
- ⑥The list of papers published related to the dissertation should be appended. Clearly indicate the section of the dissertation (which chapter) that relates to the published articles.
- ⑦Photographs should be reproduced in color in all copies of the bound dissertation.

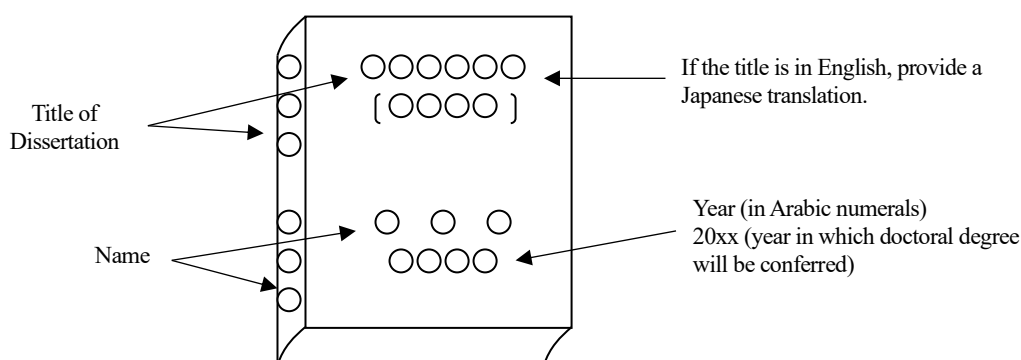

※ Please ensure that the front cover of your dissertation should be in the format shown above.

(2) Summary of dissertation

- ①The summary should be printed on the form provided by the UGSAS (in MS Word format).
- ②Figures or chemical symbols should be clearly printed or copied.

(3) Papers related to dissertation

①Related papers are publications in academic journals that are related to the theme of the dissertation and they should be accepted after the applicants' entrance of UGSAS. In principle, the candidate should be the first author of these publications.

The related papers should already have been published or should have been accepted for publication. For articles not yet published, official letters confirming that the articles will be published, or a publisher's contract should be attached. (For articles not yet published, one reprint of each article should be submitted to the UGSAS after publication.)

If the applicant is unable to submit a letter of acceptance for publication of the academic paper at the time of application for the doctoral degree, the applicant must submit a certificate of submission showing that the paper has been or will be published, by 17:00 on the two days before the date of the dissertation defense (excluding holidays).

②For related papers published with co-authors, the applicant must have had a major role in the research, and the publications must not have previously been submitted to any university for the purposes of

obtaining an academic degree by any of the co-authors.

VI Dissertation Defense

Only doctoral dissertation that satisfy all of the evaluation items of ‘Doctoral Dissertation Defense Criteria for the United Graduate School of Agricultural Sciences, Tottori University’ can be accepted as dissertations.

In principle, the defense should be an open oral examination related to the content of the dissertation, held at the participating university to which major supervisor is affiliated.

Candidates will be informed the date and time of the defense on the website of the UGSAS.

(1) Course Doctoral

An oral or written examination related to the dissertation should be carried out to ascertain that the candidate has a wide knowledge.

(2) Dissertation Doctorate

An oral or written examination should be carried out to ascertain that the candidate has a wide knowledge of the specialized field, equal to or exceeding the level of students who obtain the doctoral degree after completing the doctoral course. Content of this examination should cover subjects related to the content of the dissertation. In this case, candidates should also prove proficiency in one foreign language (by describing method).

VII Submission of dissertation after dissertation and final examinations

The full text of the doctoral dissertation (in PDF format) and one copy (or two copies if the UGSAS approves the request not to publish the full text on the Internet within a year after the date of conferment of a doctoral degree.) of the bound–cover PhD dissertation should be submitted to the UGSAS, at least one week before the doctoral degree conferment ceremony.

In addition, if the summary of the doctoral dissertation is published within three months after the date of conferment of a doctoral degree and part thereof is omitted for certain reasons, the summary of the doctoral dissertation (Form No. 13: in MS Word format) should also be submitted.

In addition, if the abstract of the doctoral dissertation (Form No. 14: in PDF format) is published under unavoidable circumstances, the abstract of the doctoral dissertation (Form No. 14: in PDF format) should also be submitted.

(Appendix)

Educational experience	Research experience
Completion of a Master’s degree course at an agricultural university	5 years or more
Graduation from an undergraduate university course specializing in agriculture	8 years or more
Graduation from or completion of a university undergraduate or postgraduate course in a field other than agriculture	9 years or more
Graduation from junior college or college of technology	12 years or more
Graduation from senior high school	15 years or more
Applicants who cannot categorized above will be assessed on individually at the Graduate School Committee.	

Notes

Research experience is classified in the following terms, with the sum of all categories being the total research period.

- (1) Period spent conducting research as a full-time faculty member of an agriculture department or school of a university.
- (2) Period spent enrolled in a graduate school specializing in agriculture.
- (3) Period spent in a university graduate department specializing in agriculture (e.g., as a full-time research student)
- (4) Period spent as a full-time employee of a Japanese or foreign government-affiliated agricultural research institute or similar institution.
- (5) Period spent gaining other experience judged by the Graduate School Committee to be of equal or greater worth than the above categories.