

# The United Graduate School of Agricultural Sciences, Tottori University

## Guide for submitting a Doctoral thesis

### I Requirements for submitting a thesis

#### (1)Course Doctoral

- ① Students who have studied for 2 years and 8 months or over in UGSAS under tuition for the doctor's program and get more than 12 credits (the students who entered before Mar. 31 2008 must attend seminars for 60 hours or over).
- ② Students who have studied more than 1 year and 8 months and achieve very high standards in their research activities, and are recommended by their major supervisors.
- ③ Students who intend to submit their Doctoral Thesis should have two or more papers published in "Journals" issued by the professional Societies. Joint authorship is permitted: in this case, the student must be the first author.

#### (2)Dissertation Doctorate

- ① Leaving UGSAS with completion of three or more years in UGSAS, obtainment of at least 12 credits (the students who entered before Mar. 31 2008 must attend seminars for 60 hours or over), under necessary supervision.
- ② Passing the doctoral degree application qualification assessment. (See Appendix for qualification assessment application criteria.)
- ③ In lieu of ① or ② above, at least four publications (Students who meet definition(2)① within one year of their leaving from UGSAS: two or more publications) closely related to their PhD dissertation in peer-reviewed, academic journals. These can include co-authored papers if the student is the first author.

### II Submission period

- (1)Students who intend to obtain a Doctor's Degree within the years required for completing their course of study (3 years) :

Applicants should submit their thesis before the middle of December for April admission (the middle of June for October admission) of the third year of UGSAS.

- (2)Students who are studying over three years, those who are qualified for I(1)②, or applicants for Dissertation Doctorate :

Applications can be submitted at any time, though, doctoral degrees shall be conferred twice a year, in September and March. Please be sure to submit documents for application by the specified date. Please note that those who are qualified for I(1)② should pass the preliminary review board.

- (3)Students who drop out UGSAS after they submit their thesis :

Thesis result shall be decided at the next General Academic Staff Meeting and their completion will be dated back to their leaving date.

### III Documents to submit

#### (1)Course Doctoral

- |  |               |
|--|---------------|
| ① Application for doctoral degree (Form No. 1-1)   | 1 copy        |
| ② List of publications (Form No. 2, also of sub publications)  | 1 copy        |
| ③ Doctoral thesis (in Japanese or in English)  | 8 copies      |
| ④ Summary of doctoral thesis<br>(Form No. 3: About 2,000 characters in Japanese or about 1,200 words in English<br>in 2 A4 papers.                                 | 1 copy        |
| ⑤ Articles related to the doctoral thesis published in academic journals, and other articles that serve as references.   | Each 8 copies |
| ⑥ Curriculum vitae (Form No. 4)  | 1 copy        |
| ⑦ If papers related to the thesis have not yet been published, submit official letters confirming that the articles will be published or the publisher's contract. | Each 1 copy   |
| ⑧ If papers related to the thesis have co-authors, summaries of joint-worked publication (Form No.5)   | Each 1 copy   |
| ⑨ Agreement(extent undertaken by the applicant letters of consent from co-authors) (Form No. 6)  | Each 1 copy   |
| ⑩ Notification Form of Internet Publication of Doctoral Thesis (Form No. 15)   | 1 copy        |
| ⑪ If the full text cannot be published through the Internet, application for publication of doctoral thesis (Form No. 12)  | 1 copy        |
| ⑫ Electronic File of ②, ④, ⑥ and ⑧ (in MS Word format)   |               |

## (2)Dissertation Doctorate

- |  |             |
|--|-------------|
| ① Application for doctoral degree (Form No. 1-2)                 | 1 copy      |
| ②~⑫ Same as (1)Course Doctoral                                   |             |
| ⑬ Certificate of Final School Graduated :                        | 1 copy      |
| ⑭ Certificate of Research History(Form No. 7) :                  | Each 1 copy |
| ⑮ Recommendation from a Major-Supervisor :                       | 1 copy      |
| ⑯ Proposal for the examination of foreign language(Form No. 8) : | 1 copy      |
| ⑰ Examination Fee :  | 57,000 yen  |

## IV Submission procedures

- (1) All documents should be submitted in person or by mail to the Academic Affairs Section of the United Graduate School of Agricultural Sciences, Tottori University.
- (2) Payment of examination fee should be cleared on the day whose application was approved by the President of Tottori University.
- (3) Students intending to submit thesis must consult with and obtain the permission of the major -supervisor first.

## V Guidelines for doctoral thesis, Summary of doctoral thesis, and related papers

### (1) Doctoral thesis

- ①The thesis should be printed on A4 size white paper. A typed version is preferred.
- ②Temporary binding is acceptable for the thesis when first submitted. After passing the examination, five bound-cover theses must be submitted at least one week before the doctorate conferment ceremony and they should meet the following requirements.  
Color and kind of cover paper: Not specified  
Font color: Black  
Size: 30cm(long)×21cm(wide) (standard A4 size paper)
- ③If the thesis is written in Japanese, the Japanese title on the front cover should be followed by an English title in parentheses. If the thesis is written in English, the English title on the front cover should be followed by a Japanese title in parentheses.
- ④The cover must also have the name of the author and the year of the final submission of the thesis (i.e., submission of bound-cover copy after passing the examination).
- ⑤English and Japanese summaries should be provided on the last page of the thesis.
- ⑥The list of papers published related to the thesis should be appended. Clearly indicate the section of the thesis (which chapter) that relates to the published articles.
- ⑦Photographs should be reproduced in color in all copies of the bound thesis.

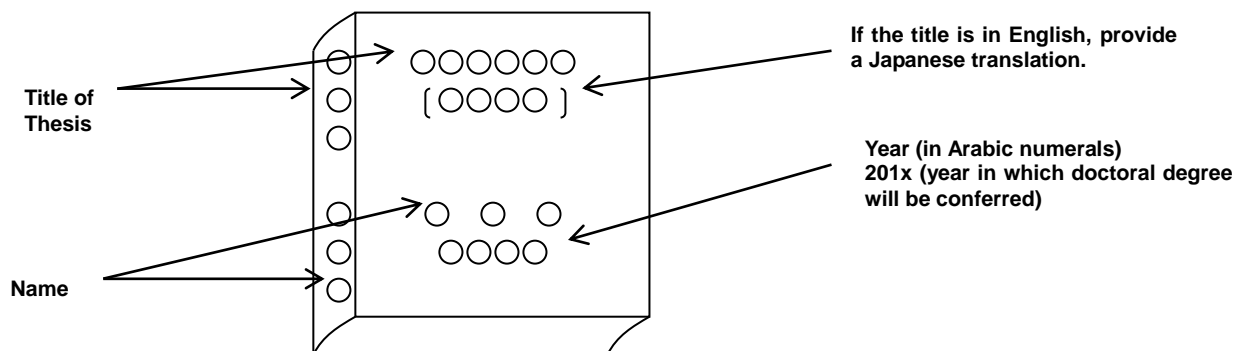

\* Please ensure that the front cover of your thesis should be in the format shown above.

### (2) Summary of thesis

- ①The summary should be printed on the form provided by the UGSAS (in MS Word format).
- ②Figures or chemical symbols should be clearly printed or copied.

### (3) Papers related to thesis

- ①Related papers are publications in academic journals that are related to the theme of the thesis and they should be accepted after the applicants' entrance of UGSAS. In principle, the candidate should be the first author of these publications.

The related papers should already have been published, or should have been accepted for publication. For articles not yet published, official letters confirming that the articles will be published or a publisher's contract should be attached. (For articles not yet published, three reprints of each article should be submitted to the UGSAS after publication.)

- ② For related papers published with co-authors, the applicant must have had a major role in the research, and the publications must not have previously been submitted to any university for the purposes of obtaining an academic degree by any of the co-authors.

## VI Examination

Only doctoral thesis that satisfy all of the evaluation items of ‘Doctoral Dissertation Examination Criteria for the United Graduate School of Agricultural Sciences, Tottori University’ (Cf. 27 page) can be accepted as dissertations.

In principle, the examination should be an open oral examination related to the content of the thesis, held at the participating university to which major supervisor is affiliated.

Candidates will be informed the date and time of the examination on the Website of UGSAS.

### (1) Course Doctoral

- ① An oral or written examination related to the dissertation should be carried out to ascertain that the candidate has a wide knowledge.

### (2) Dissertation Doctorate

- ① An oral or written examination should be carried out to ascertain that the candidate has a wide knowledge of the specialized field, equal to or exceeding the level of students who obtain the doctoral degree after completing the doctoral course. Content of this examination should cover subjects related to the content of the dissertation. In this case, candidates should also prove proficiency in one foreign language (by describing method).

## VII Submission of dissertation after dissertation and final examinations

The full text of the doctoral thesis (in PDF format), three copies (or five copies if the UGSAS approves the request not to publish the full text on the Internet within a year after the date of conferment of a doctoral degree) of the bound–cover PhD dissertation should be submitted to the UGSAS, at least one week before the doctoral degree conferment ceremony. In addition, if the summary of the doctoral thesis is published within three months after the date of conferment of a doctoral degree and part thereof is omitted for certain reasons, the summary of the doctoral thesis (Form No. 13: in MS Word format) should also be submitted.

In addition, if the abstract of the doctoral thesis (Form No. 14: in PDF format) is published under unavoidable circumstances, the abstract of the doctoral thesis (Form No. 14: in PDF format) should also be submitted.

\*\*\*\*\*

### (Appendix)

Educational experience	Research experience
Completion of a Master’s degree course at an agricultural university	5 years or more
Graduation from an undergraduate university course specializing in agriculture	8 years or more
Graduation from or completion of a university undergraduate or postgraduate course in a field other than agriculture	9 years or more
Graduation from junior college or college of technology	12 years or more
Graduation from senior high school	15 years or more
Applicants who cannot categorized above will be assessed on individually at the Graduate School Committee.	

#### Notes

Research experience is classified in the following terms, with the sum of all categories being the total research period.

- (1) Period spent conducting research as a full-time faculty member of an agriculture department or school of a university
- (2) Period spent enrolled in a graduate school specializing in agriculture
- (3) Period spent in a university graduate department specializing in agriculture (e.g., as a full-time research student)
- (4) Period spent as a full-time employee of a Japanese or foreign government-affiliated agricultural research institute or similar institution
- (5) Period spent gaining other experience judged by the Graduate School Committee to be of equal or greater worth than the above categories